

HORIZONTAL FORM FILL SEAL MACHINES



Horizontal Form Fill Seal Machines

AHM

The AHM range of horizontal form, fill and seal machines from Audion is ideal for the packaging of individual products. The range starts with a small tabletop machine up to high speed floor models. The product is fed to the machine either manually or automatically, and neatly wrapped and sealed in packaging film. All the AHM machines are easy to operate and flexible in use. Bag dimensions can easily be changed to suit various package sizes and lengths. The adjustable former comes as a standard and allows you to change the bag width without tools. The constantly heated seal bars are suitable for a wide range of packaging materials, such as PP, CPP, OPP, laminated, lacquered and other various complex films.

Main features of the AHM

- User friendly control panel
- Friction feed wheels with quick release system
- Easy bag length adjustment
- Adjustable seal pressure
- End of film detection
- Adjustable bag former
- Product feeding conveyor with pushers
- Product contact areas made of stainless steel and food approved materials
- Safety covers
- Digital temperature controllers
- Bi-active sealing
- CE compliant

Options

- Servo control
- Print registered film capability
- Gas flush for modified atmosphere packaging (MAP)
- Euro slot or various other hole punch systems
- Stainless steel covering
- Support stand for tabletop models
- Date coder

Complementary equipment

- Automatic feeding systems
- Discharge conveyors
- Conveyor belt feeding units

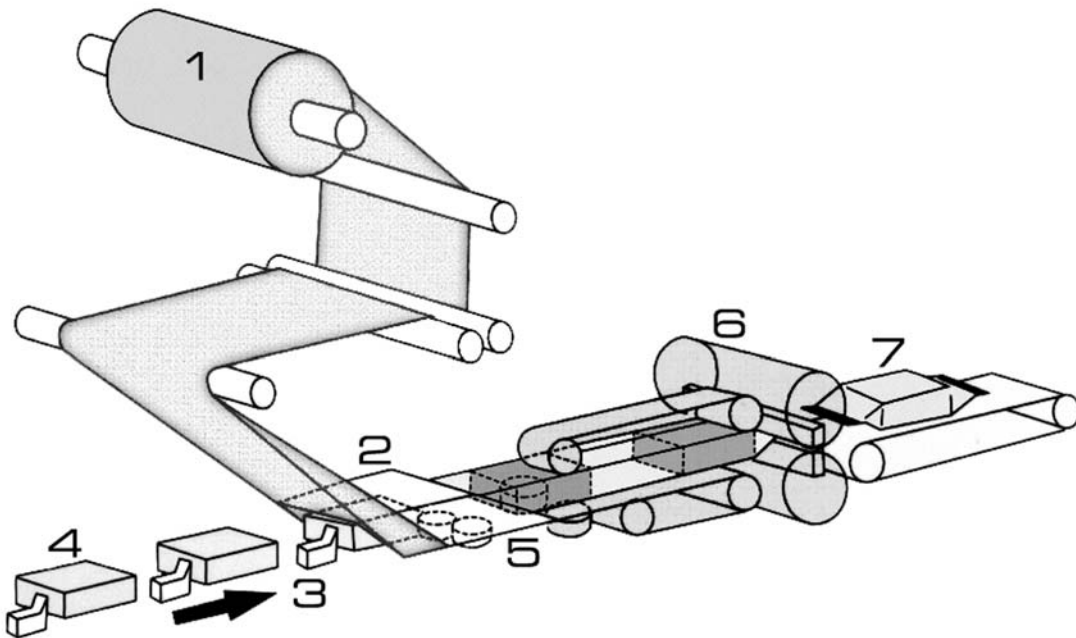

1 = film
2 = bag former

3 = infeed conveyor chain
4 = product

5 = center seal
6 = end seal and cutter

7 = packed product

AHM 350T

The versatile AHM 350T is Audion's smallest horizontal flow wrapper. The 350T is easy to operate and suitable for individually wrapping all types of products. The product is manually placed on the feeding conveyor and automatically wrapped. The adjustable former is suitable for a film width of 80-350 mm. The packaging speed is adjustable and the maximum capacity of the machine is 60 bags/min.

Main features AHM 350T

- User friendly control panel
- Friction feed wheels with quick release system
- Easy bag length adjustment
- Adjustable seal pressure
- End of film detection
- Adjustable bag former
- Product feeding conveyor with food grade pushers
- Stainless steel product contact areas
- Safety covers
- Digital temperature controllers
- Bi-active sealing
- CE compliant

Options

- Gas flush for modified atmosphere packaging (MAP)
- Print registration capability
- Euro slot or various other hole punch systems
- Stainless steel frame
- Date coder
- Machine stand with casters



AHM 350TPH + support



AHM 350T + Date coder

Technical specifications	AHM 350T
Bag length (min-max)	80-250 mm
Film width (min-max)	80-350 mm
Max. film roll diameter	320 mm
Inner film roll diameter	75 mm
Max. product height	60 mm
Max. product width	120 mm
Capacity*	60 bags/min
Machine dimensions (LxWxH)	1640 x 830 x 900 mm
Machine weight	240 kg
Voltage	230 V - 1 Ph - 50/60 Hz
Consumption	2000 W

*Capacity is dependent on packaging material, product, environment, etc.

AHM 350/450/600

The AHM 350/450/600 are the floor models in the horizontal form, fill and seal machine range. The long feeding conveyor and the stable construction make it possible to run these machines automatically at high speeds, achieving an output of up to 250 packages per minute. The electronic eye for bag registration is a standard feature. Most of the adjustments are done electronically and when one setting is changed (bag length for example), all other settings are made automatically. This feature allows for quick and easy product changeover.

The AHM 350/450/600 is available in two different versions. The I type, which has a servo control and a touch screen user interface, and the H type, with inverter controlled motors and an analogue control panel.

Main features of the AHM 350/450/600

- Compact construction
- 2 meter product feed conveyor with food grade pushers
- User friendly control panel
- Friction feed wheels with quick release system
- Print registered film capability
- Easy bag length adjustment
- Adjustable seal pressure
- End of film detection
- Adjustable bag former
- Stainless steel product contact areas
- Outfeed conveyor
- Safety covers
- Digital temperature controllers
- CE compliant
- Servo driven (I type only)

Options

- Gas flush for modified atmosphere packaging (MAP)
- Euro slot or various other hole punch systems
- Stainless steel frame
- Date coder
- Automatic feeding systems
- Infeed and product takeaway conveyors



AHM 450H

Technical specifications	AHM 350/450/600 H	AHM 350/450/600 I
Bag length (min-max)	80 - 320 mm (100 - 360 mm for 600)	80 - 320 mm (100 - 360 mm for 600)
Film width (min-max)	80 - 350/ 450/ 600 mm	80 - 350/ 450/ 600 mm
Max. diameter film roll	300 mm	300 mm
Inner diameter film roll	75 mm	75 mm
Max. product height	50 mm / 65 mm* / 65 mm*	50 mm / 65 mm* / 65 mm*
Max. product width	120 mm/ 120 mm/ 230 mm	120 mm/ 120 mm/ 230 mm
Capacity**	20-150 bags/min	30 - 250 bags/min (30 - 150 for 600)
Machine dimensions (LxWxH)	4000 x 1150 x 1525 mm	4000 x 1150 x 1525 mm
Machine weight	800/ 850/ 900 kg	800/ 850/ 900 kg
Voltage	230 V - 1 Ph - 50/ 60 Hz	400 V- 3 Ph - 50/ 60 Hz
Consumption	3 kW	3,8 kW

*optional 120 mm

**Capacity is dependent on packaging material, product, environment, etc.