

AUDION Power Sealer XL - PSR TC XL & PSR PLUS XL



Power Sealer XL comes in two models: Power Sealer Temperature Controlled XL (PSR TC XL) and the Validatable Power Sealer PLUS XL (PSR PLUS XL) which can be used in validated processes for optimized product control and packaging safety.

Both models are stainless steel impulse sealers, specifically engineered for effortless sealing of extra-large PE/PA films, aluminum laminates, and anti-static materials. Built with a heavy-duty frame and high-performance bi-active sealing bars, these machines handle thick and specialized films with ease—ensuring maximum protection for your products.

With an impressive sealing length of 2500 mm, the PSR XL enables fast production of large, custom-made bags and dust covers for oversized components or high-volume goods. Each seal is straight, strong, and consistent, with a secure width of 8 mm.

Vacuum and/or gas flush options:

PSR XL models can be equipped with an integrated vacuum and/or gas flush system: the VAC PSR XL and VAC PSR PLUS XL. These vacuum models are standard fitted with a wide nozzle, preventing the film from being drawn into the nozzle and ensuring a smooth and reliable vacuum process. For Modified Atmosphere Packaging (MAP), the machine can perform a multi-cycle vacuum and gas flush sequence (up to 5 cycles if required), optimizing the shelf life of perishable products.

Specifications	PSR TC XL / PSR PLUS XL
Model	Floor model
Type of machine	Extra-large industrial impulse sealer
Operation	Easy-to-use Audion Touch Techware
Pre-set seal parameters	Up to 50 seal parameters can be stored
Covering	Stainless steel
Max. seal length	2500 mm
Seal width	8 mm
Adjustable height	Seal Height electrically adjustable 1289 mm standard + 200 mm
Type of package	Readymade bags / create custom bags
Film types	PE, PP, Aluminum laminate, anti-static films Paper laminate + PP/PE/PET and Tyvec
Branche / Applications	Various, Food, Industrial Parts, Medical & Laboratory, Pharmaceutical Industry
Validatable	Yes (PSR PLUS XL models only)
Validation requirements	Conforms to the validation requirements of ISO 11607-2 and its guidance ISO/TS 16775
Sealing requirements	Conforms to the sealing requirements of EN 868-5 and DIN 58953-7
Machine dimensions (WxDxH)	2400/2900 x 982 x 1289+200 mm
USB-port	USB-port for data logging
Type of product	Industry, Granulate, Powder, Solid
IP value	IP20
Low Voltage directive	NEN-EN-IEC 60204-1:2018

Options:

- Cutting device (only for PSR TC XL & PSR PLUS XL without vacuum system)
- Barcode scanner (to change the critical seal parameters automatically)
- Worktable (to support products during the sealing process)

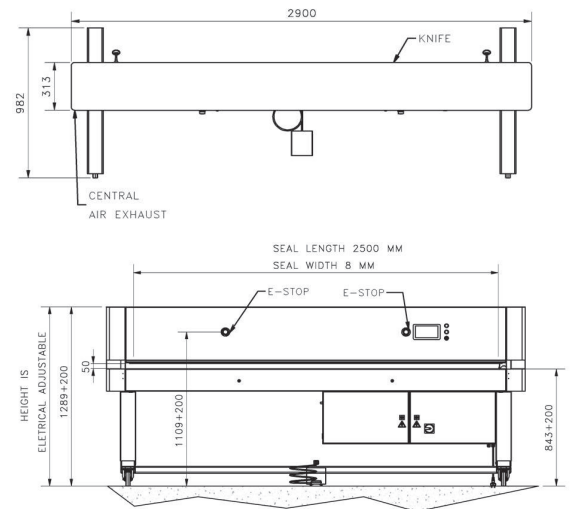

Note: Dimension sketch of PSR XL 2500 without vacuum system

Advantages:

- Stainless steel covering AISI 304
- Suitable for sealing various modern film types
- Capable of sealing extra-large bags / dust covers up to 2500 mm
- Powerful pneumatic seal bars guaranteeing a perfect 8 mm seal over the entire length
- Easy-to-use Audion Touch Techware
- Store up to 50 preset seal settings
- USB-logging of seal-parameters
- PSR PLUS XL models for validated processes